

ELEVATION 1
 SCALE: 1/2" = 1'-0"

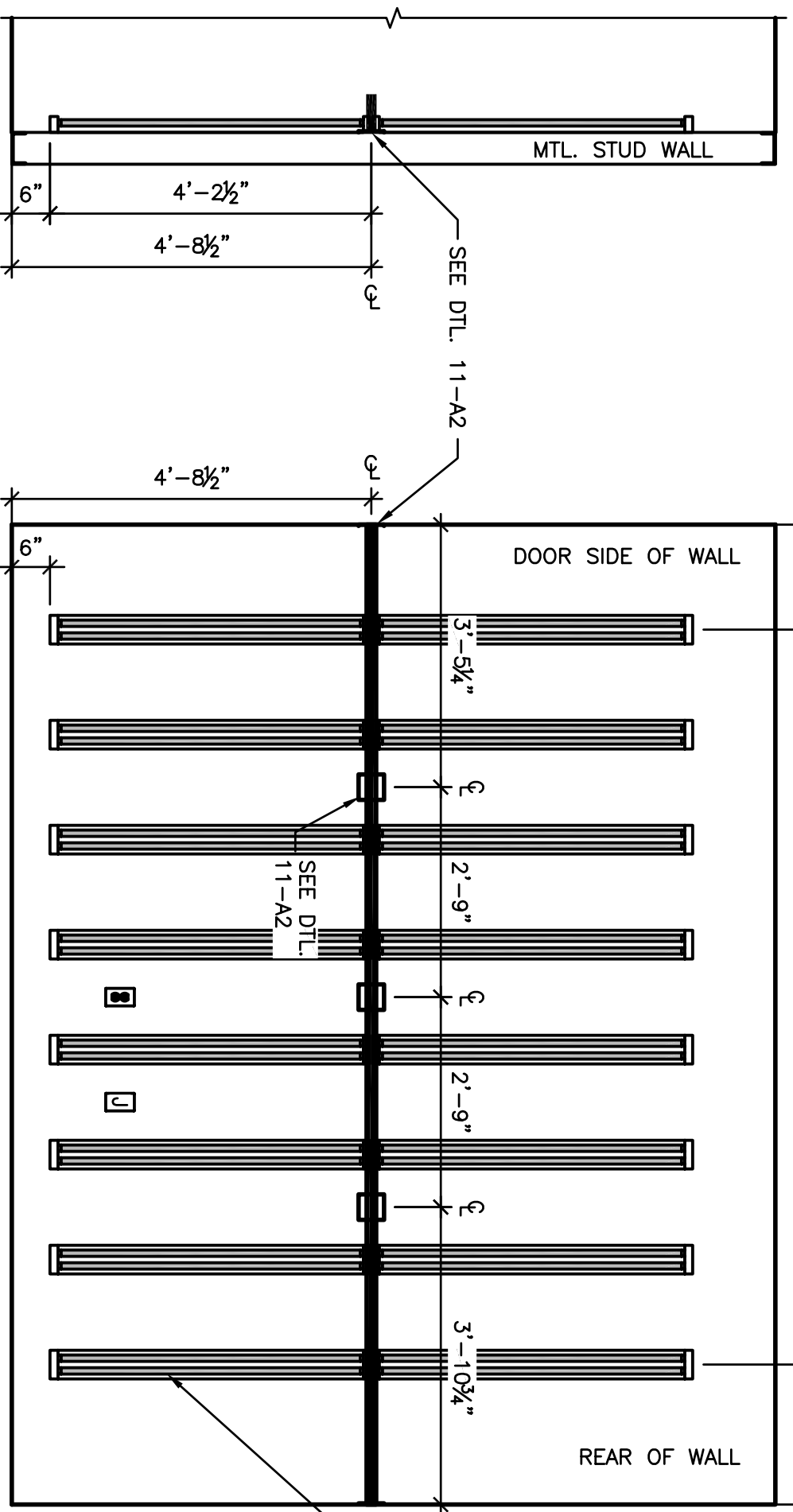

ELEVATION 2
 SCALE: 1/2" = 1'-0"

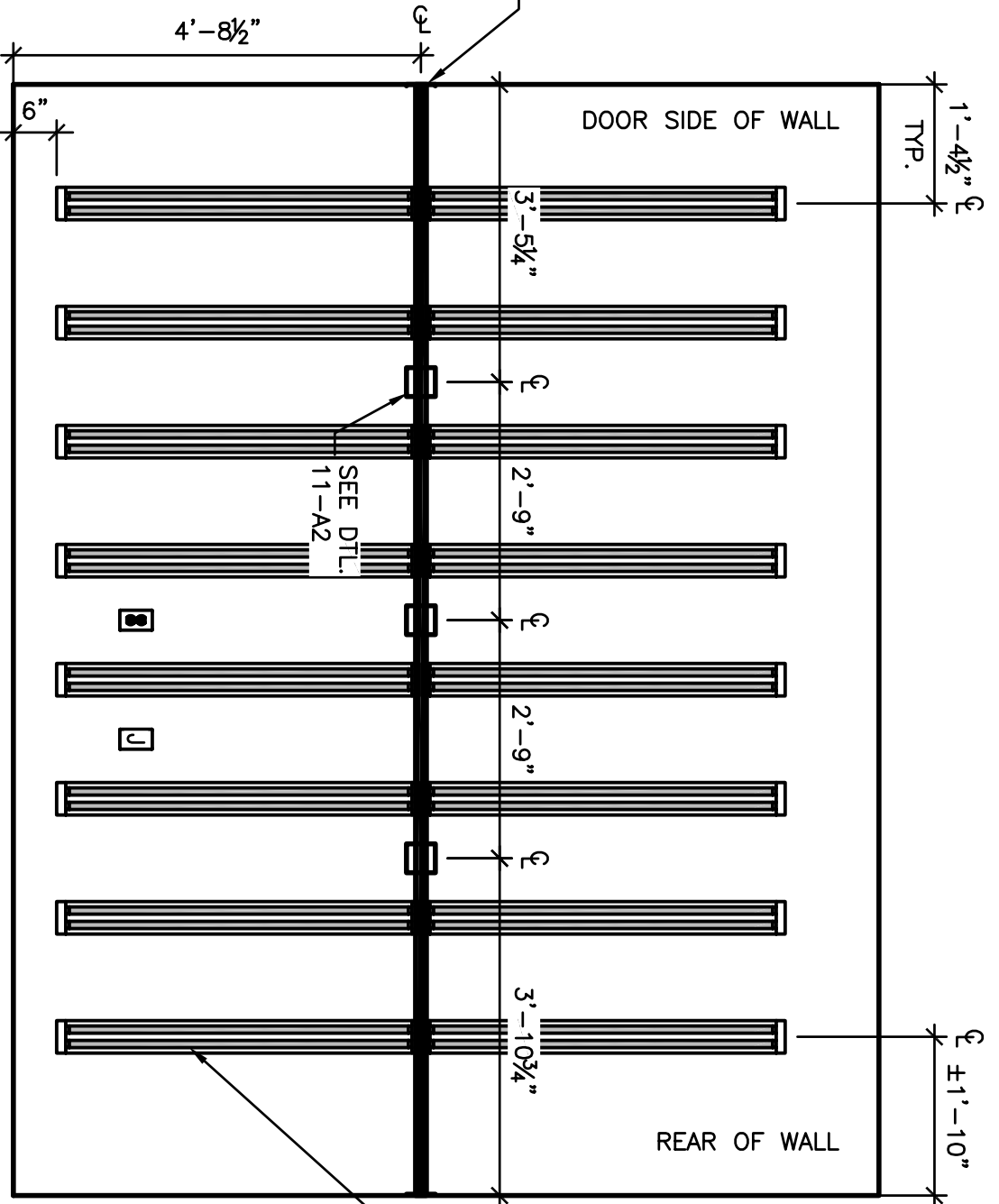

ELEVATION 3
 SCALE: 1/2" = 1'-0"

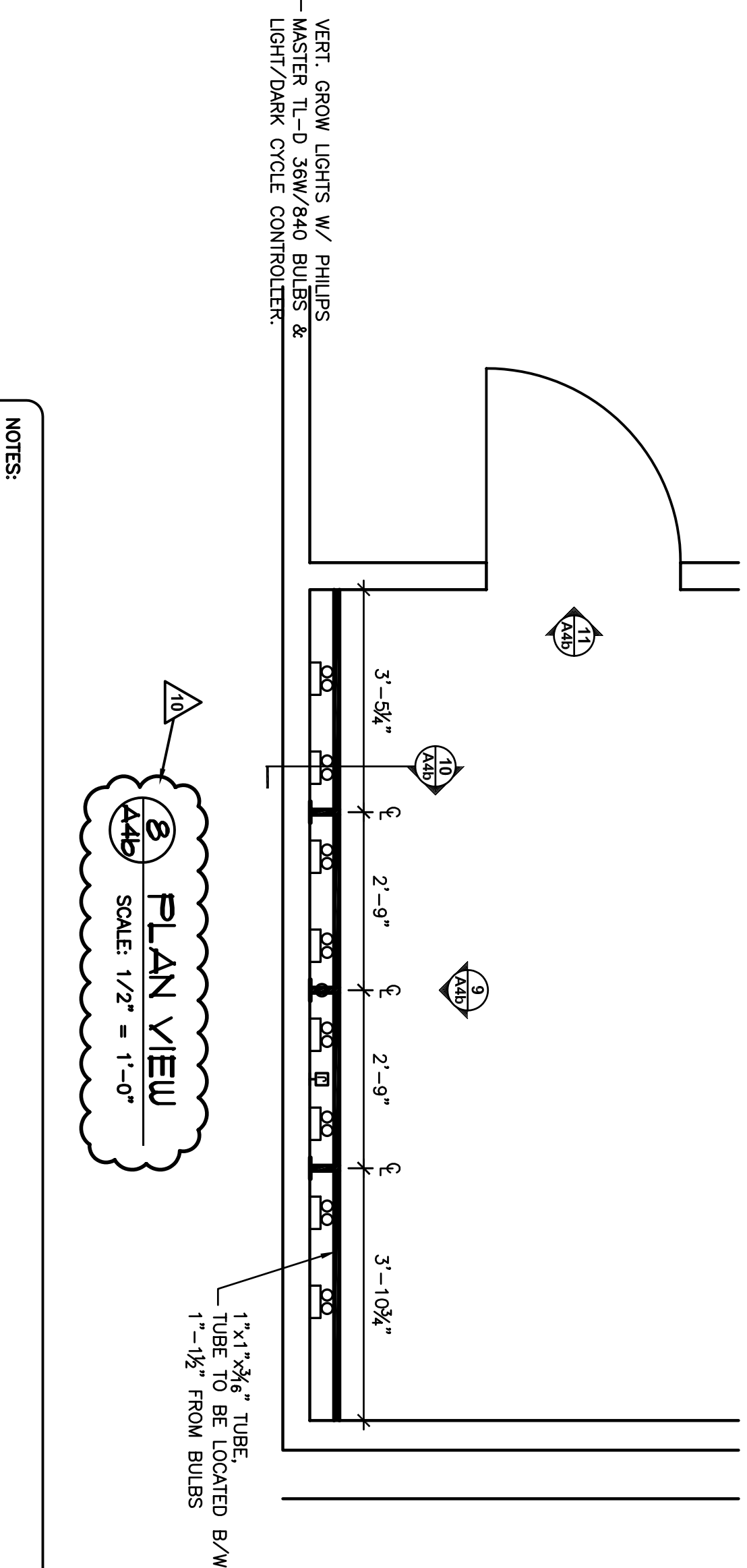

PLAN VIEW 4
 SCALE: 1/2" = 1'-0"

NOTES:
 ALL SHELVES TO RECEIVE LIGHT DUTY UPRIGHTS & BRACKETS, EXCEPT DTL. 3-44b & 7-44b.
HEAVY DUTY:
 -UPRIGHTS RUBBERMAID (2) 48" BLACK TWIN TRACK
 -BRACKETS RUBBERMAID UTILITY SINGLE BLACK TRACK
 -SHELVES 3/4" OAK PLYND, STAINED TO MATCH TENANT SAMPLE & SEALED W/ POLYURETHANE W/ 1" HARDWOOD EDGE BANDING, 8" MAX. SHELF LENGTH.
LIGHT DUTY:
 -UPRIGHTS RUBBERMAID UTILITY SINGLE BLACK TRACK
 -BRACKETS RUBBERMAID SINGLE BLACK TRACK
 -SHELVES 3/4" OAK PLYND, STAINED TO MATCH TENANT SAMPLE & SEALED W/ POLYURETHANE W/ 3/4" HARDWOOD EDGE BANDING, 8" MAX. SHELF LENGTH.

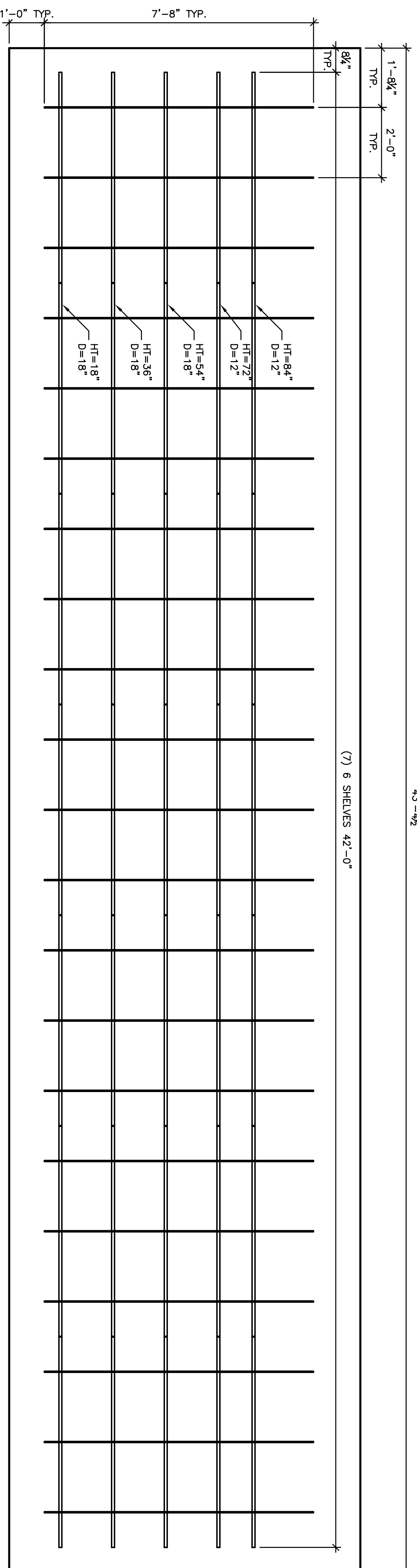

ELEVATION 5
 SCALE: 1/2" = 1'-0"

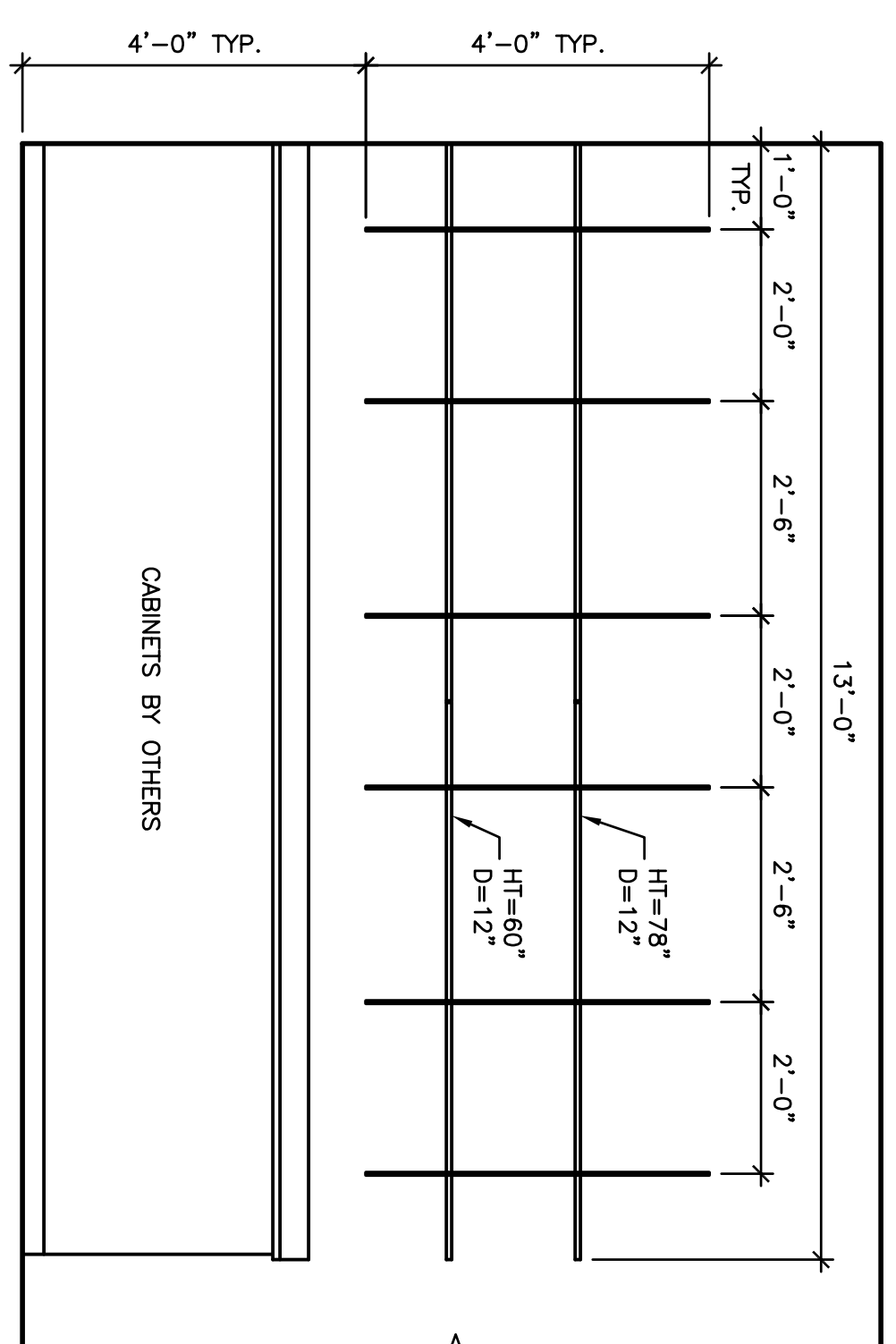

ELEVATION 6
 SCALE: 1/2" = 1'-0"

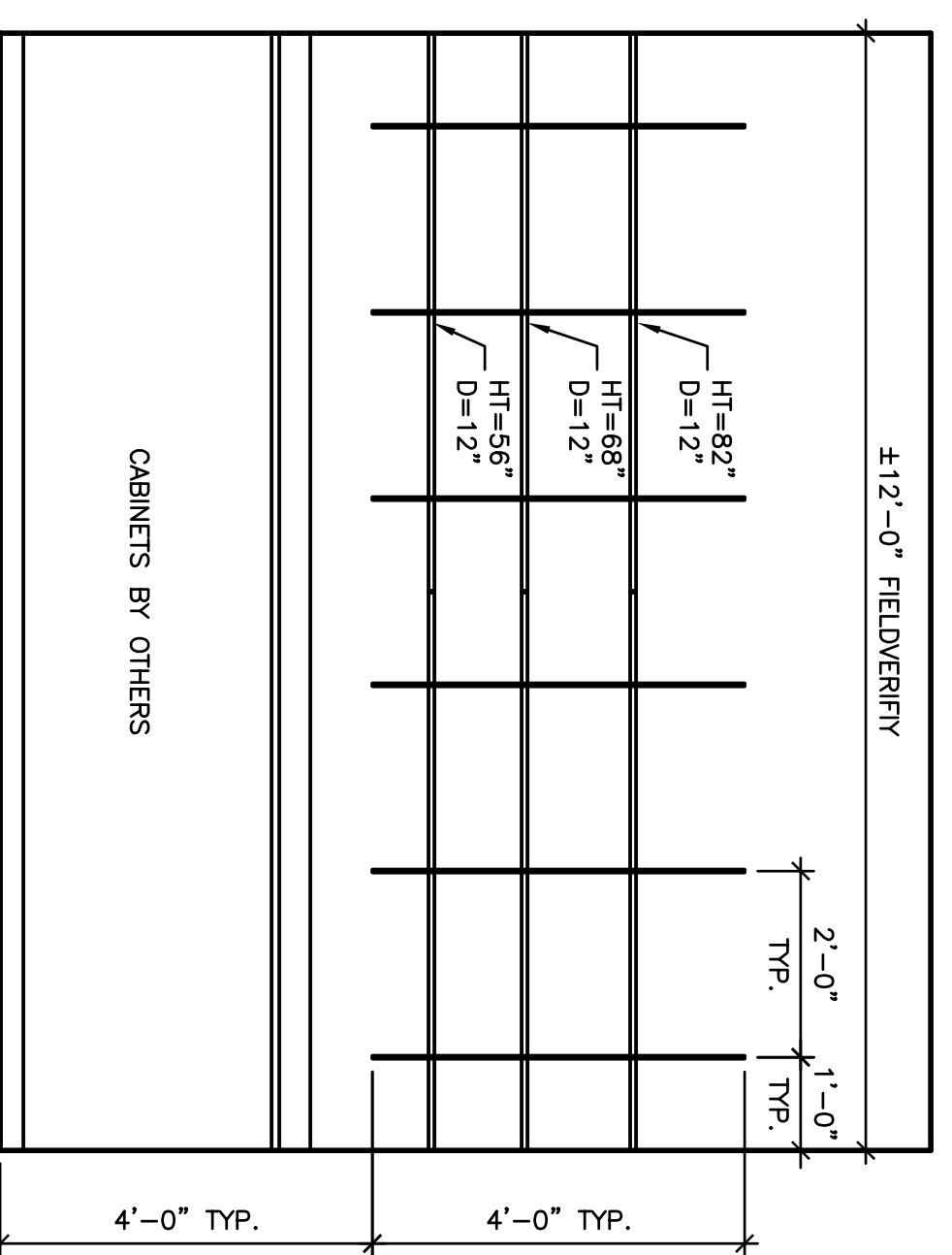

ELEVATION 7
 SCALE: 1/2" = 1'-0"

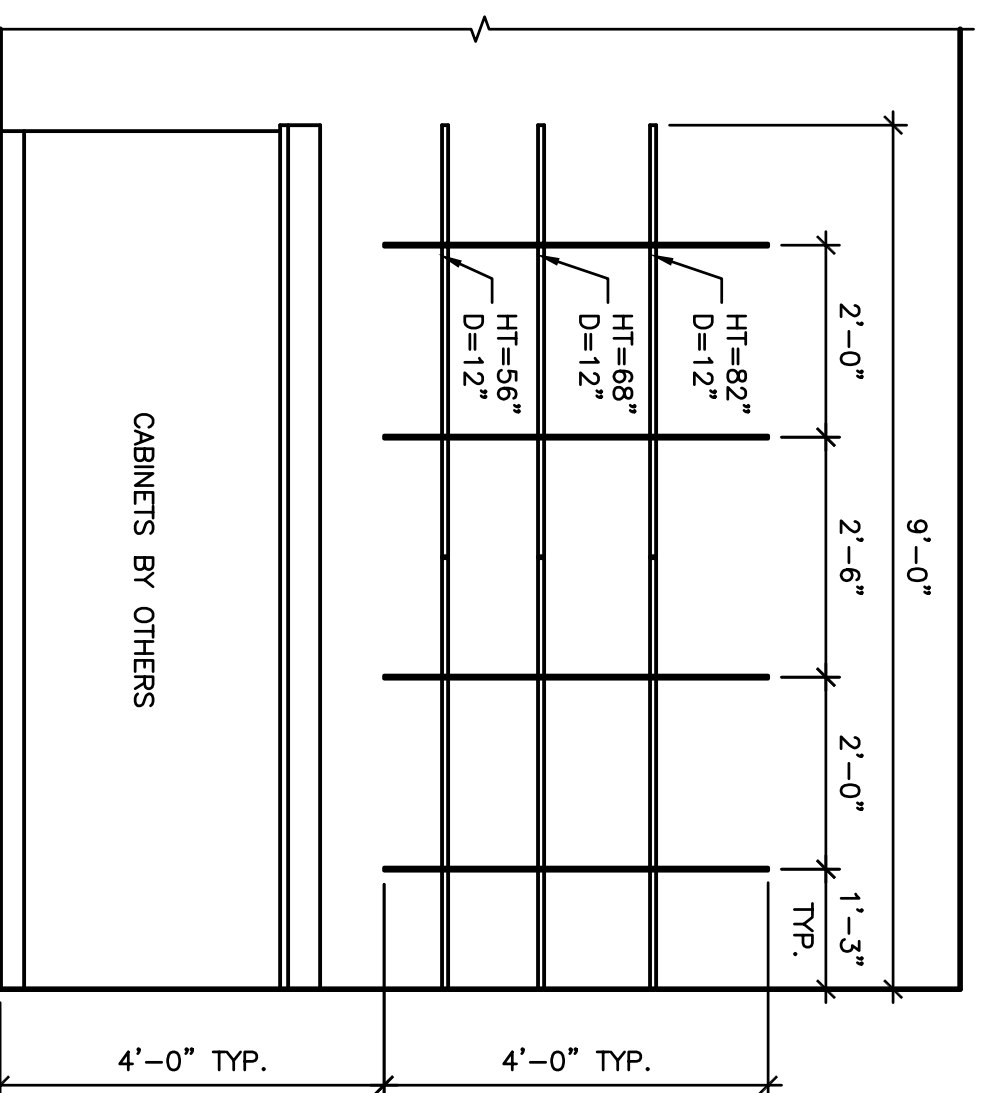

ELEVATION 8
 SCALE: 1/2" = 1'-0"

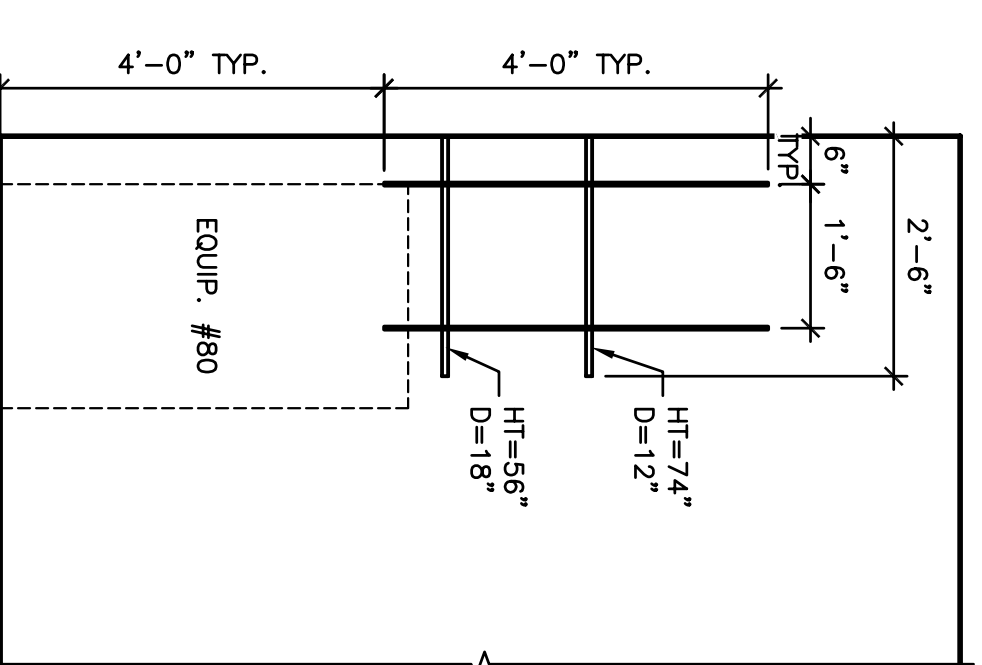

ELEVATION 9
 SCALE: 1/2" = 1'-0"

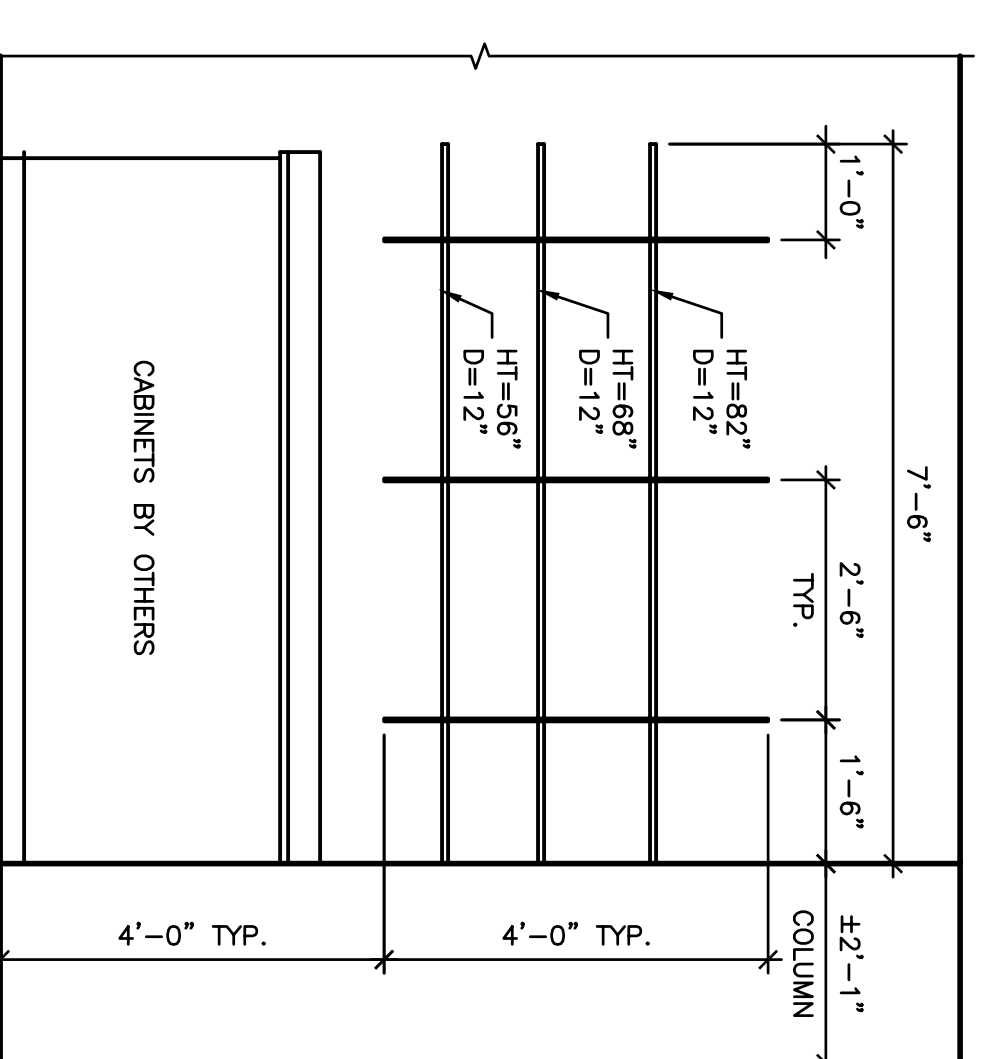

ELEVATION 10
 SCALE: 1/2" = 1'-0"

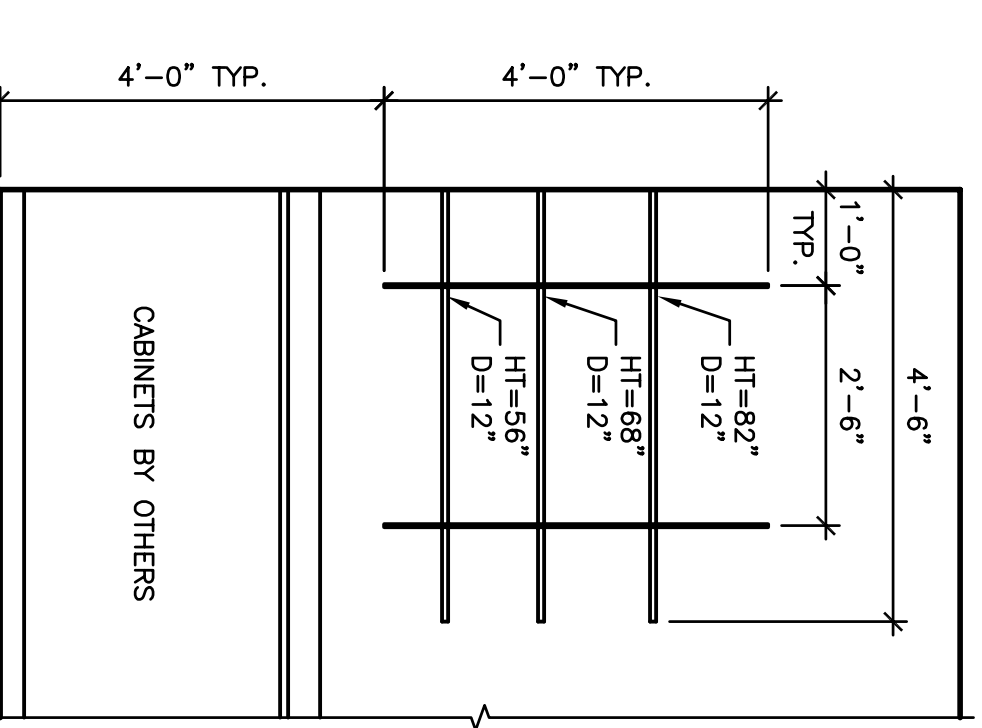

ELEVATION 11
 SCALE: 1/2" = 1'-0"

Approved by

Boyer
 CropScience
 LP

Lubbock
 Santa Fe 32
 LTD.